

10 9 8 7 6 5 4 3 2 1

REVISIONS				
REV.	DATE	DESCRIPTION	ECO	BY
A	3/7/2007	PRODUCTION RELEASE. WIRES 1 AND 3 REVERSED	11558	VC

NOTES:  
 1. REFER TO GOOD CRIMPS AND HOW TO RECOGNIZE THEM.  
[HTTP://WWW.MOLEX.COM/TNOTES/CRIMP.HTML#RULES](http://www.molex.com/tnotes/crimp.html#rules)  
 2. TAG & BAG WITH STAR TRAC PART NUMBER, REVISION AND DATE OF MANUFACTURE, APPROX. AS SHOWN.

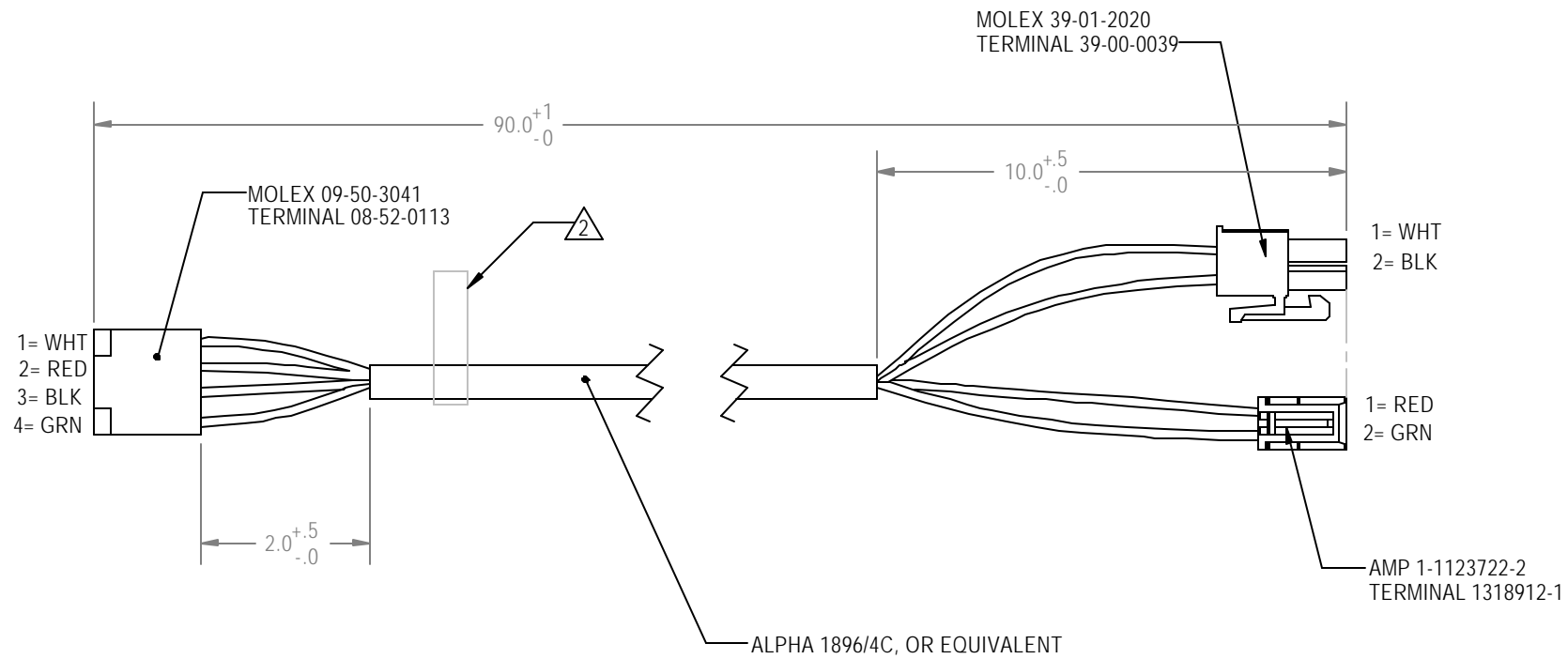

**DOCUMENT STATUS:**  
**RELEASE**

NOTICE OF PROPRIETARY INFORMATION  
 THIS DOCUMENT SHALL NOT BE REPRODUCED NOR SHALL THE INFORMATION CONTAINED HEREIN BE USED BY OR DISCLOSED TO OTHER EXCEPT AS EXPRESSLY AUTHORIZED BY UNISEN

MATERIAL	TOLERANCES UNLESS OTHERWISE SPECIFIED			UNISEN, INC. DBA <b>STAR TRAC</b> 14410 Myford Road Irvine CA 92606
	SEE BOM	X.XX = ± .100 X.X = ± .25 X = -.0/+5	ANGLES = ± 2° FRACTIONS = ± 1/32	
FINISH	DRAWN	VC	DATE	REV <b>A</b>
	N/A		01-31-07	
	CHECKED			
	APPROVED			
		U.O.M.	INCH	TITLE <b>HARNESS, DC SUPPLY, PRO TR</b>
				SCALE: 1:2 SHEET 1 OF 1 SHEET SIZE: A

10 9 8 7 6 5 4 3 2 1